



Midmark Electric Lift Table Manual



<i>Table of Contents</i>	
Pre-Installation	2
Parts Identification	2-3
Installation	3
Installation with Scale Option	4
Scale Features/Operation	4-5
Troubleshooting	5
Care & Cleaning	6
Specifications	6
Product Warranty	7

Pre-Installation



WARNING

Do not move surgery table by yourself. Improper handling may result in injury or damage to the product.



WARNING

Never Place foot on the table's base or under the table top.

Note

Save all packaging until certain you are satisfied with the product.

Open packages carefully. Inspect the shipping carton and contents for any visible damage. The Electric Lift Exam Table is fully assembled and contained within one carton on a pallet. If ordered with optional built-in scale, the scale display and cords are contained within a smaller box within the carton on pallet. The display will need to be plugged into the power outlet and mounted onto the Electric Lift Exam Table. See installation instructions.

Parts Identification

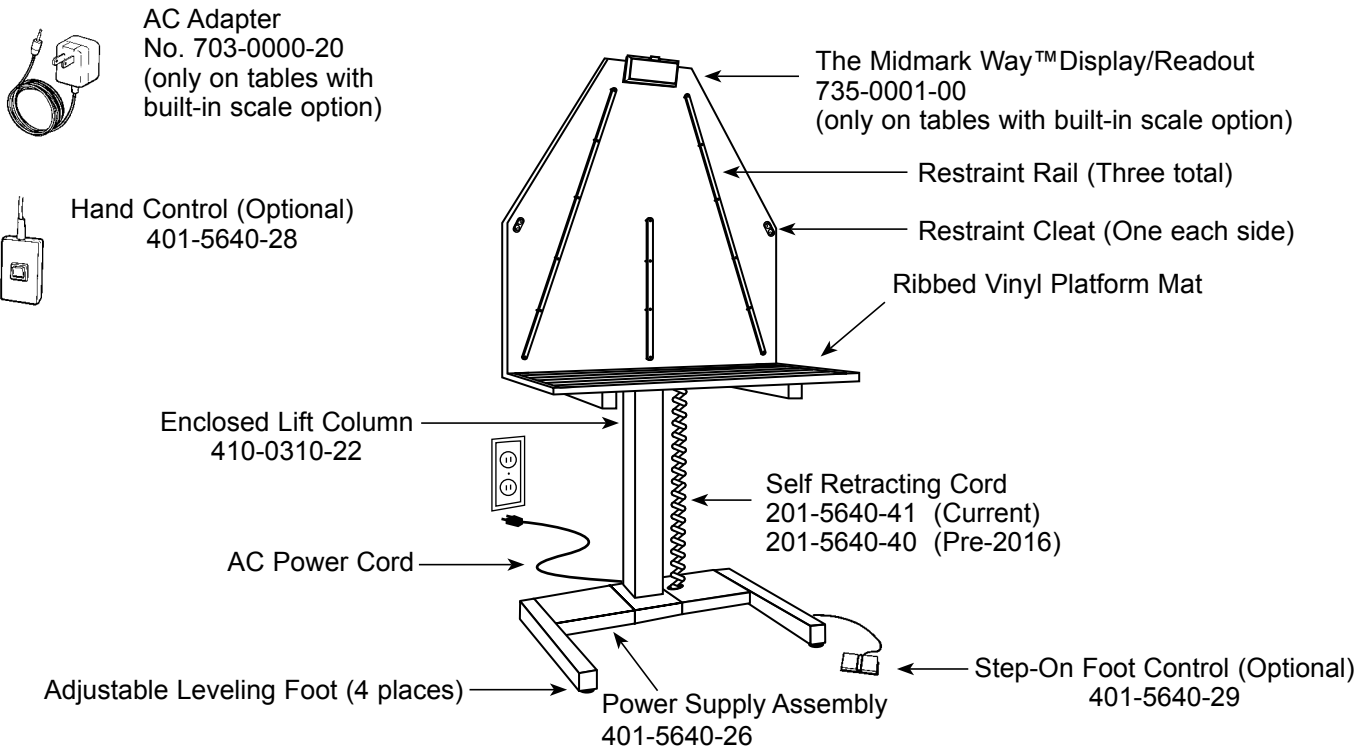

- No. 101-5640-01
- No. 101-5640-07
- No. 110-0310-00
- No. 110-0310-01

- Electric Lift Exam Table with Hand Control
- Electric Lift Exam Table with Foot Control
- Electric Lift Exam Table with Scale with Hand Control
- Electric Lift Exam Table with Scale with Foot Control

Parts Identification *continued*

Restraint Options

Animals can be restrained on the Electric Lift Exam Table using one of these three methods:

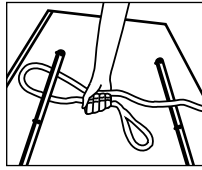

1. Make a loop with the leash and thread it behind the restraint rail. Bring the end of the leash through the loop and pull both ends of the leash to tighten.

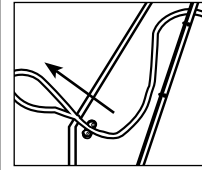
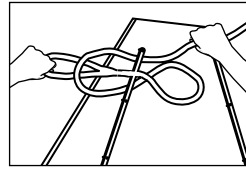

2. Thread leash behind restraint rail and through restraint cleat.

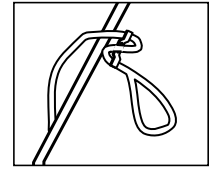

3. Bring leash around the back of the table and secure to figure eight tie-down.

Installation

After removing the table from its packaging, the table is ready to be placed in the desired position within your facility. The table is very heavy, so we recommend using a four-wheeled furniture cart to make moving easier. If a cart is not available we suggest having four strong people to lift and move the table.

To Lift the Electric Lift Exam Table:

When moving the electric lift exam table, NEVER lift the table by the stainless steel top! Lower the table top to its lowest position. This will be the position the table has arrived in.

Stand the table upright by grasping the lift column at the top center of the exam top back. Do NOT use the restraint cleat rails or stainless steel top as handles!

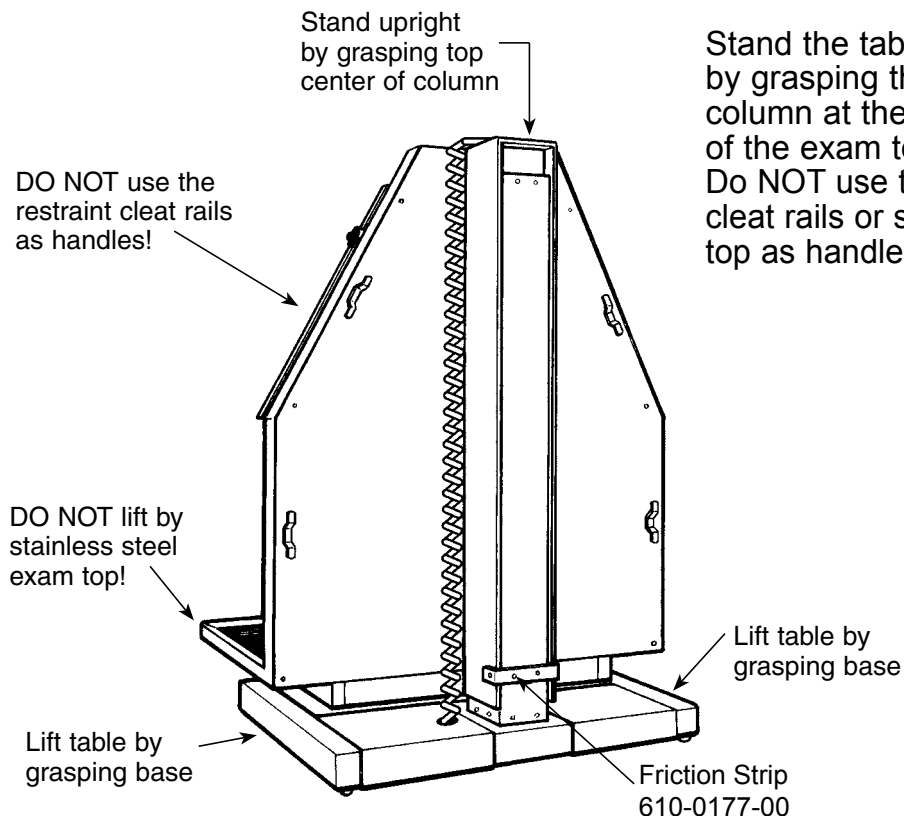

Installation with Scale

Refer below for connecting instructions if installing a lift table with the optional scale built-in.

1. Remove the scale/readout display from the small box that was enclosed within the carton on the pallet.
2. Plug the AC adapter cord and display cord into the back of the scale readout/display. (The display cord will be the straight cord extending from the exam top.)
3. Plug the A/C adapter into a 110v power outlet.

4. Hang the scale readout/display over the top back of the stainless steel exam top.

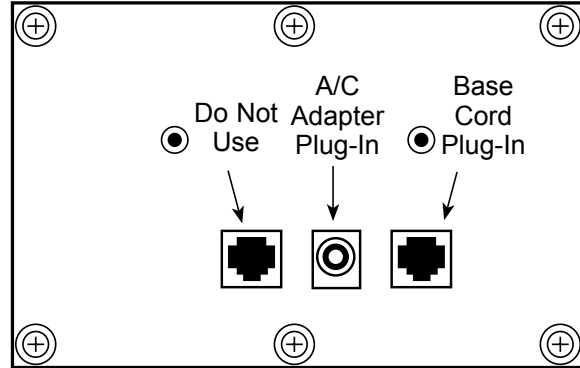

Back view of Display/Readout

Scale Features/Operation

Using The Control Panel:



Push to turn unit on. Display shows the following:

AAAA – self test

Midmark – checks display segments

u 1.7 – software revision

b xx.x – battery voltage (varies with AC plug in and internal 9v battery.) A reading of 6.0v indicates the need for battery replacement; the unit will shut off at a reading of 5.5v.

0.0 – ready to weigh



Push and hold until display indicates unit shift.

Display will show “conv” until the conversion is complete.



Push the RECALL button – The display will show the message “rECL” then alternately flash between the last stable weight and the “rECL” message. Press ON/ZERO button to return to normal weighing. Works only with hold function active.

Features:

Tare Function:

Any weight within the scale capacity can be zeroed out by pressing the ON/ZERO button. When the weight is removed, the display flashes the tared weight. Press ON/ZERO button to return to normal weighing.

Weighing Function:

Display will blank out until a close range of the weight is reached. With the hold function active, the display will show the stable weight and the “hold” indication. The displayed weight will lock until the weight is removed. **continued**

Scale Features/Operation continued

Weight Hold:

Press and hold the ON/ZERO button and the RECALL button. Display will show “zero” then “h on” or “h off”. Release buttons when selection is made. Default setting is “h on”.

Automatic Shut Off:

In AC mode, the indicator will shut off in one hour. In battery mode, the indicator will shut off in one minute.

Calibration:

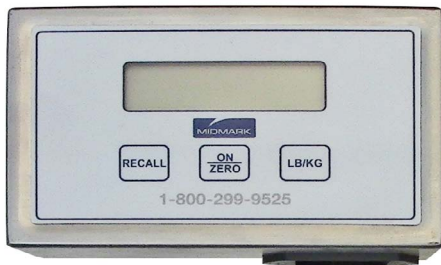

- 1) Install fresh 9 volt battery in indicator.
- 2) Unplug indicator's AC adapter from back of indicator.

- 3) Press and hold ON/ZERO button and LG/KG button. The display will change from “zero” to “CAL0” in about 3 seconds.
- 4) With an empty platform press the ON/ZERO button. The indicator will count down from “16” to “1” and display “C50”.
- 5) Place a 50 lb. weight on platform and press the ON/ZERO button. The indicator will countdown from “16” to “1”. Display will show “50”.
- 6) Remove the 50 lb. weight and press the ON/ZERO button. The scale is calibrated and automatically returned to normal weight mode.
- 7) Re-plug AC adapter into indicator.

Switching from AC to DC:

Unplug the AC adapter from the wall. Unplug the cord from the display. Press the ON/ZERO button to turn indicator on.

Switching from DC to AC:

Plug the AC adapter into a standard wall socket and the cord into the AC outlet on the back of the display. Press the ON/ZERO button to turn indicator on.

Troubleshooting

Indicators:

Messages on the readout indicate operating condition:

- OL Indicates weight on scale exceeds capacity or malfunction of scale display.
- OPEN Indicates malfunctioning of base or cable, or scale needs calibrated.



Indicates batteries are discharged.

In The Event Of A Problem:

In the event that a problem occurs, a Midmark technician is ready to assist you. In order to save time, please check the following items before calling:

- Does the readout display have a message that indicates what the problem is? Refer to “Indicators” at left for descriptions.
- Check all cables/connections.
- Unplug AC power and battery, then plug-in again to reset the scale.

Midmark Tech Support: 1-800-643-6275

Care & Cleaning

The Electric Lift Exam Table may be cleaned with any commercially available product recommended for use on stainless steel. Frequent cleaning will prolong the life and help maintain the natural luster of the stainless steel.

To prevent scratching, use a soft cloth to clean the stainless steel exam surface. If scrubbing is necessary, use a nylon or plastic type scrubber. When cleaning, always rub in the direction of the “grain” of the metal.

To remove minor scratches, we recommend using a 3M ScotchBrite[®] scouring pad rubbed lightly in the direction of the “grain” of the metal.

Never use steel wool or steel brushes when cleaning stainless steel. Steel particles may become embedded into the stainless steel and cause rust.

Avoid use of chlorine bleach for cleaning. Chlorides, bromides, iodides and thiocyanates will cause pitting, corrosion and discoloration of the metal. If using bleach, clean thoroughly with water to completely remove bleach residue.

Avoid excessive moisture. The Electric Lift Exam Table contains electronic components that may be damaged by excessive exposure to moisture. When cleaning the table or mopping the floor around the table, do not use excessive water or leave the table in standing water.

Specifications

Exam Surface Dimensions:	44" x 22"
	Height adjusts 7" to 38 1/2"
Overall Dimensions:	44" x 31"
	Max height 84 1/2" when raised
Lift Capacity:	225 pounds
Scale Capacity (optional):	300 pounds
Scale Accuracy:	Within 0.2% at 300 pounds
Electrical:	Operates on standard 110 VAC



Caution

Never attempt to exceed the lift capacity of 225 pounds.

Product Warranty

This product is warranted for 1 year from the date of delivery to the original purchaser only. If equipped with the built-in Midmark Scale, the scale is warranted for 2 years. The warranty is only applicable if customer complies with all instructions and specifications furnished by Midmark relating to installation, care, and application. The customer agrees not to modify, misapply, or misuse product in any manner which deviates from the Midmark instructions. Any repairs, alterations, or services provided by parties other than Midmark or its authorized representatives may void warranty. The buyer is responsible for all freight charges on returned items.

Product Satisfaction Policy

In the event that the customer is not fully satisfied with the products purchased, Midmark may, at its own discretion, arrange for the customer's account to be credited (excluding shipping charges) or replace the product. The customer must notify Midmark of any claim of nonconformity or defect in writing within 30 days from the date of receipt. The product must be returned to Midmark in its original packaging, undamaged and showing no unusual wear within 20 days of the customer's written notice.

To return an item, follow these simple instructions:

- Call Midmark for complete instructions (800-643-6275)
- A sales representative will give you a Return Authorization Number
- If a Restocking Fee applies, you will be informed at this time
- Label the boxes with the Return Authorization Number
(All items must have a Return Authorization Number)
- Return the items, postage/freight prepaid

If necessary, the Midmark sales representative will assist you with freight arrangements.

Note: Custom orders and/or custom colors may not be returned.

Midmark Corporation - Carthage Facilities

1000 Civil War Road

Area 5

Carthage, MO 64836

[1-800-643-6275](tel:1-800-643-6275)

